

# FPSI 1010-2 Dual Channel Panel Mounting LED Status Indicator

The FPSI 1010-2 consists of two channel 3-level voltage indicators. It is designed to be easily panel mounted. Each channel of the module compares an input voltage with a defined voltage window. The colour of the display shows whether the input voltage is below, within or above this window. The indicator is powered from a 7 to 24Vd.c. supply and provides a red-green-red bright LED indication over a 0 to 30Vd.c. measurement range. The user can easily set the colour switching thresholds. Hysteresis is built-in to avoid chattering at the colour switching thresholds. The module incorporates 1 trigger output per channel, allowing the user to drive external alarms or control one or two processes being monitored. A low power mode is available, whereby the module indicates the voltage level by flashing the relevant colour, instead of indicating solid colours. Connection is via screw terminals. The module features a rectangular plastic snap-in bezel, typically requiring a 24.6 x 12.4mm (0.97 x 0.49") cut-out.

## FEATURES

- Bright Red and Green Indication
- Separate 0 to 30Vd.c. Measurement Inputs
- 7 to 24Vd.c. Supply Voltage
- 2 User Programmable Thresholds per Channel
- 1 Control Output (Negative Logic) per Channel
- Snap-in Plastic Bezel
- Screw Terminal Connections
- Easy to Set up and Use



## TYPICAL APPLICATIONS

- Go - No Go Indication
- Level Monitoring
- Alarm Indication
- Control

## ORDERING INFORMATION

Standard Indicator

Stock Number  
FPSI 1010-2

## ELECTRICAL SPECIFICATIONS

Specification	Min.	Typ.	Max.	Unit
Supply voltage (V+ to 0V)	7.0		24.0*	Vd.c.
Supply current		40		mA
Input Voltage (Vin1 to 0V and Vin2 to 0V)	0		30	Vd.c.
Internal resolution (Channel 1 and Channel 2)		30		mVd.c.
Accuracy (overall error) (Channel 1 and Channel 2)		2		%
Temperature stability		100		ppm/°C
Hysteresis		2		%
Sample rate		4		Samples/sec
Operating temperature range	-30		50	°C
Input impedance (unscaled input Vin1 and Vin2)		1		kOhm
Output High Voltage (Alm1 and Alm2)	4.175		5.125	Vd.c.
Output High Current (Alm1 and Alm2)			1	mA
Output Low Voltage (Alm1 and Alm2)	0		0.6	Vd.c.
Output Low Current (Alm1 and Alm2)			1	mA

\* Operation of the indicator beyond the maximum supply voltage rating may cause permanent damage to the indicator.

## SAFETY

To comply with the Low Voltage Directive (LVD 93/68/EEC), input voltages to the module's terminals must not exceed 60Vdc. The user must ensure that the incorporation of the FPSI 1010-2 into the user's equipment conforms to the relevant sections of BS EN 61010 (Safety Requirements for Electrical Equipment for Measuring, Control and Laboratory Use).



**Martel Electronics Corporation**  
PO Box 770  
Londonderry, NH 03053 USA

**Tel: 800-821-0023**  
**Email: sales@martelcorp.com**  
**Web: www.martelcorp.com**

# FPSI 1010-2 Dual Channel Panel Mounting LED Status Indicator

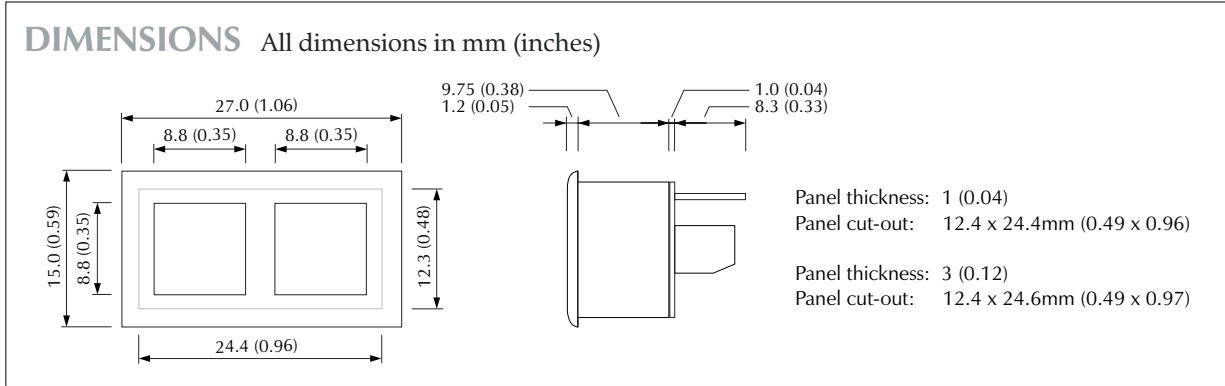
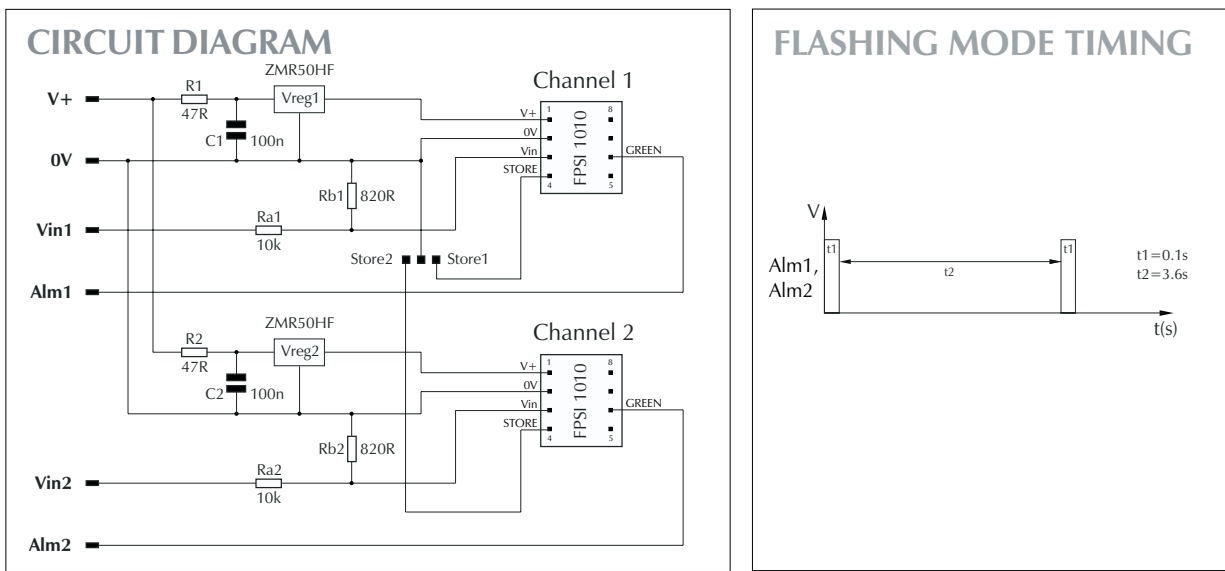

### CONFIGURING THE LEVEL INDICATOR

Each channel of the FPSI 1010-2 is factory configured with colour switching thresholds, as follows: V1 = 11.0V (nom.) V2 = 22.0V (nom.)  
 To change these settings, proceed as follows for each channel.

**Step 1**

- Remove the Store jumper link.
- Connect the V+ and 0V terminals of the FPSI 1010-2 to a 7.0 to 24.0Vd.c. supply.

**Step 2**

- Apply the first desired voltage (V1) to Vin1.
- Enable the Store1 jumper link.
- Remove and park the Store jumper link.
- The module flashes Green to indicate that the V1 level has been stored.

**Step 3**

- Apply the second desired voltage (V2) to Vin1.
- Enable the Store1 jumper link.
- Remove and park the Store jumper link.
- The module displays Red to indicate that the V2 level has been stored.

**Step 4**

- To enter solid LED mode, make sure Vin does not change.
- To enter flashing LED mode, change Vin by 1.4V or more.
- Place the Store jumper link over the 2 pins.
- Remove and park the Store jumper link.
- Module flashes Red or Green to indicate that the LED mode has been stored.

**Step 5**

- Repeat steps 2 and 3, this time using Vin2 and Store2 instead of Vin1 and Store1.

**Step 6**

- Disconnect the module. The module is now ready for use.

# FPSI 1010-2 Dual Channel Panel Mounting LED Status Indicator

## SCREW TERMINAL FUNCTIONS

- V+ Positive power supply to the status indicator.
- 0V Negative power supply to the status indicator.
- Vin1,2 Measuring inputs with reference to 0V.
- Alm1,2 These digital output terminals go Low (0V) when the voltage on their respective Vin terminals is
  - lower than the switching threshold V1 or
  - higher than the switching threshold V2.

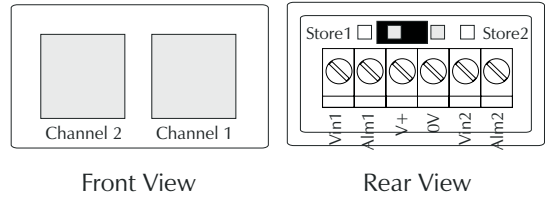

## APPLICATIONS

Do not connect more than one FPSI 1010-2 to the same power supply if the units cannot use the same signal ground. Both channels of the FPSI 1010-2 must share the same signal ground. Taking any input beyond the power supply rails will damage the FPSI 1010-2.

In the diagrams below, only one channel is shown, where Vin can be Vin1 or Vin2 and Alm can be Alm1 or Alm2 respectively. Make sure the Store jumper link is in the parked position.

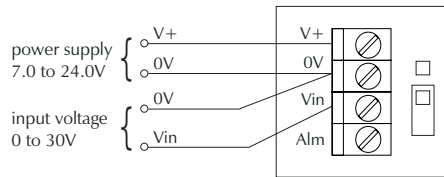

### Basic operation

- The indicator is :
- red when the Vin voltage is between 0V and V1 (Low)
  - green when the Vin voltage is between V1 and V2 (Ok)
  - red when the Vin voltage is between V2 and V+ (High)

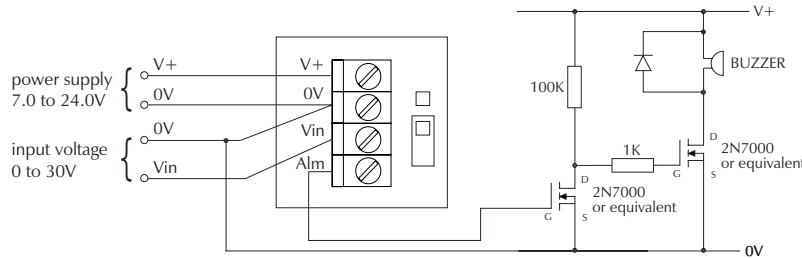

### Driving a Buzzer

The Alm output is shown driving a buzzer. Each Alm must not be allowed to source more than 1mA.

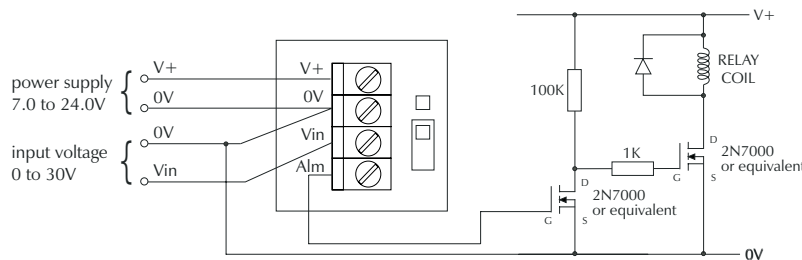

### Driving a Relay

The Alm output is shown driving a relay. Each Alm must not be allowed to source more than 1mA.

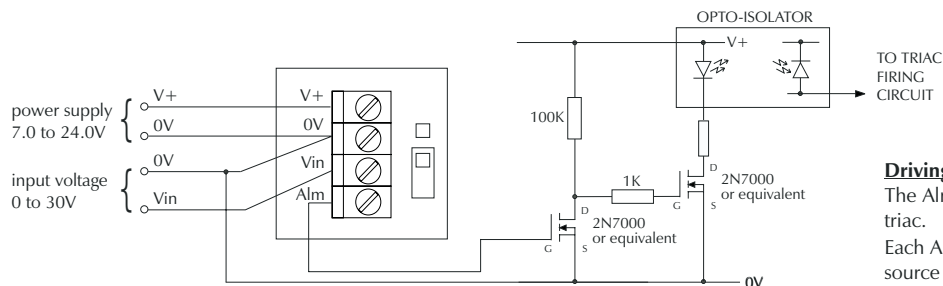

### Driving a Triac

The Alm output is shown driving a triac. Each Alm must not be allowed to source more than 1mA.

Bottom View of 2N7000



Consult the MOSFET datasheet for maximum drain current.