

This low cost, compact indicator is ideally suited for low or high volume applications. The meter features a 17 segment LCD to display 0-1V or -1V-0-1V d.c. full scale reading. Other voltages and currents can be indicated via the addition of 2 external scaling resistors. The meter can be used in applications where the order of magnitude of the reading is more important than the value of the reading itself. It allows the operator to scan the display and receive a quick visual feedback. The module is mounted into the panel, using the supplied clip. A rubber seal is included, providing splashproof protection for the unit when fitted to the meter during installation.

- 🔊 17 Segment LCD
- 🔊 LED Backlighting
- 🔊 Colour Scale
- 🔊 0-1V and -1V-0-1V d.c. Ranges
- 🔊 No Calibration Required
- 🔊 Screw Terminal Connection
- 🔊 Splashproof

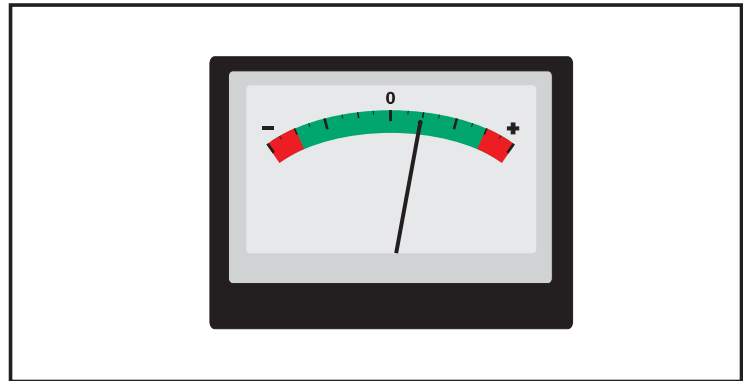

ORDERING INFORMATION

Standard Indicator

Stock Number
SP 5-1710-BL

ELECTRICAL SPECIFICATIONS

Specification		Min.	Typ.	Max.	Unit
Accuracy (overall error)*			1		Segment (± 1)
Full scale reading	(left/right hand zero position)	0		1	V d.c.
	(centre zero position)	-1		1	V d.c.
Resolution	(left/right hand zero position)		62.5		mV d.c.
	(centre zero position)		125		mV d.c.
Sample rate			4		samples/sec
Operating temperature range		0		50	$^{\circ}\text{C}$
Supply voltage (meter only, not LED backlighting)		5	9	12	V d.c.
Supply current (meter only, not LED backlighting)			6	10	mA
Supply voltage for LED backlighting**		4.5	5	5.5	V d.c.
Supply current for LED backlighting @5V d.c.**			50		mA

* At voltages above 1V d.c. or below -1V d.c., the display flashes.

** For backlighting supply voltages in excess of 5Vd.c., consult Various Operating Modes on page 4.

SAFETY

To comply with the Low Voltage Directive (LVD 93/68/EEC), input voltages to the module's pins must not exceed 60Vdc. The user must ensure that the incorporation of the panel meter into the user's equipment conforms to the relevant sections of BS EN 61010 (Safety Requirements for Electrical Equipment for Measuring, Control and Laboratory Use).

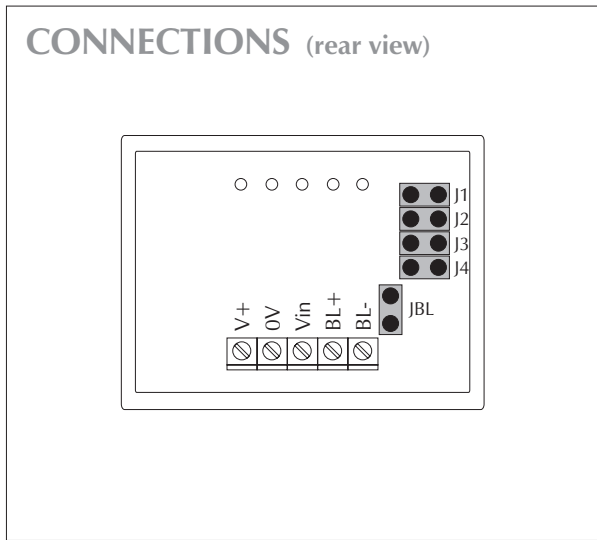
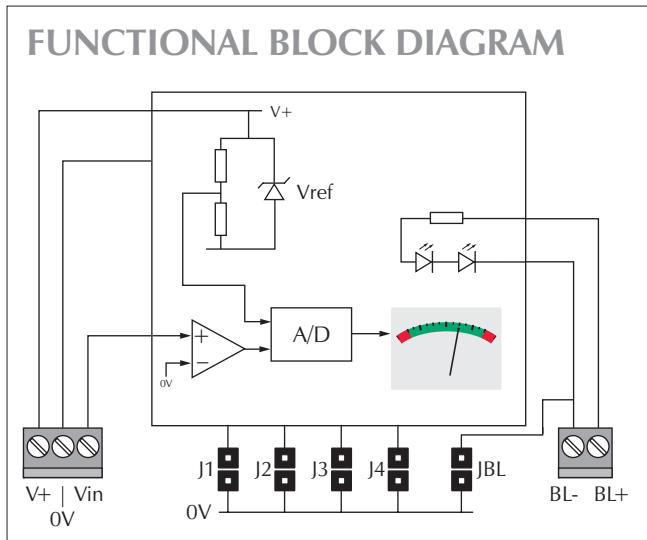
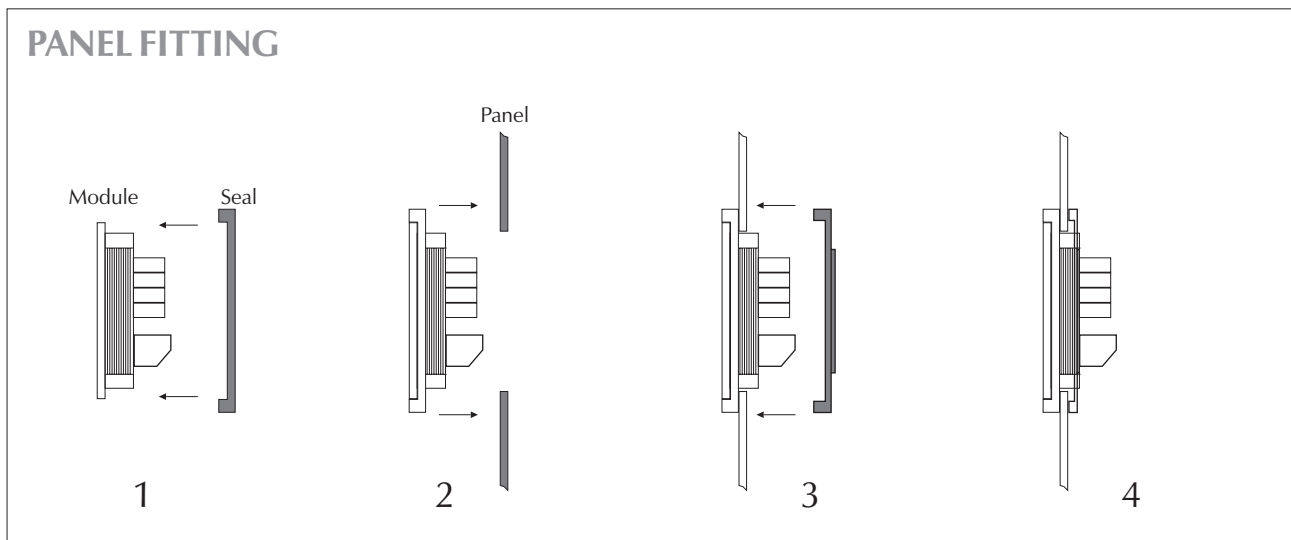
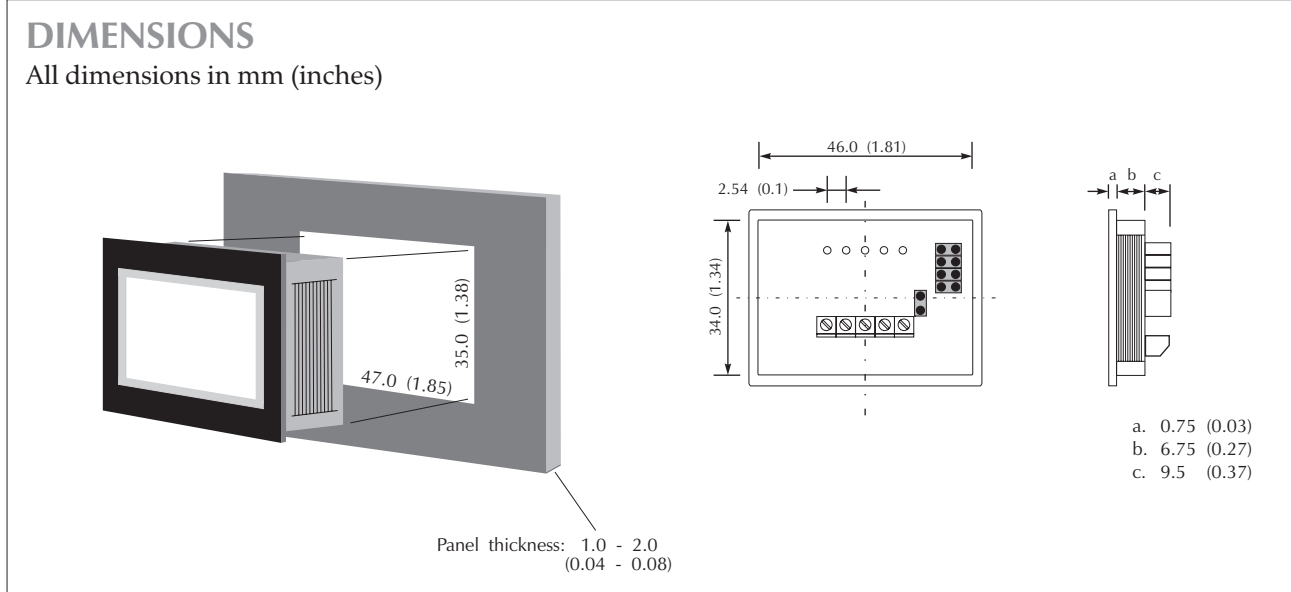

SCREW TERMINAL FUNCTIONS

- V+ Positive power supply to the meter.
- 0V 0V power supply to the meter.
- Vin Positive measuring input, with reference to 0V.
- BL+ Positive power supply to the LED backlighting.
- BL- Negative power supply to the LED backlighting.

JUMPER LINK FUNCTIONS

- J1. Not fitted: The module has a 0 to 1V d.c. full scale range (default setting).
 Fitted: The module has a -1V to +1V d.c. full scale range.
 The scale annunciators (-, 0, +) are visible. This overrides links J3 and J4.
- J2. Not fitted: The input voltage is not inverted (default setting).
 Fitted: The input voltage is inverted inside the meter.
- J3. Not fitted: The scale annunciators (-, 0, +) are not displayed.
 Fitted: The scale annunciators (-, 0, +) are displayed. This overrides link J4.
- J4. Not fitted: The scale annunciator (0) is not displayed.
 Fitted: The scale annunciator (0) is displayed.
- JBL. Not fitted: LED backlighting is not required or V+ exceeds 5V.
 Fitted: To switch on the LED backlighting when V+ = 5V, fit JBL to connect BL- to 0V.
 If V+ exceeds 5V, then a series resistor must be fitted in the backlighting circuit. See the application diagrams on this datasheet for details.

SCALING

Two external resistors may be used to alter the full scale reading of the meter - see table for sample values. Alternatively, use the following formulae to calculate Ra and Rb. Select the nearest available standard resistor. To achieve optimum accuracy, use 1% metal film resistors. Ensure solder link La is cut when fitting Ra.

Required F.S.R.	Ra	Rb
10V	910k	100k
100V	1M	10k
1mA	0R	1000R
10mA	0R	100R
100mA	0R	10R
1A	0R	1R

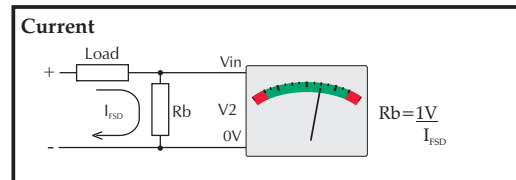
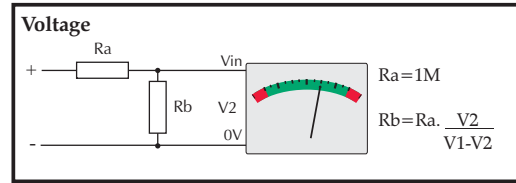

VARIOUS OPERATING MODES

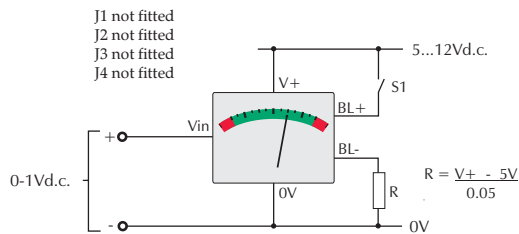

Indicating a voltage in the range 0 to 1V d.c.
Close switch S1 to turn on the backlighting.
Jumper link JBL must NOT be fitted.

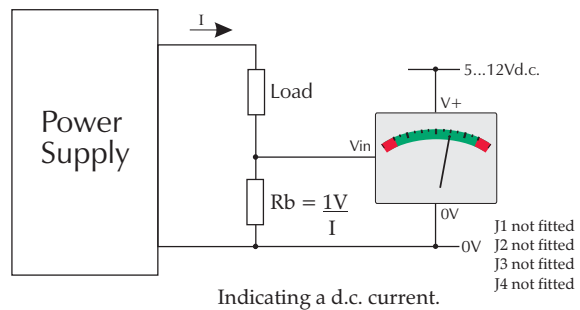

Indicating a d.c. current.

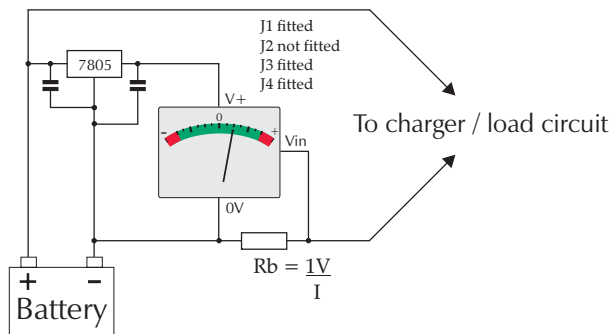

Indicating battery charge/discharge current.
Ensure jumper link LK1 is fitted.

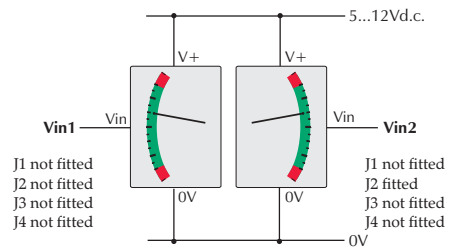

Indicating 2 voltages

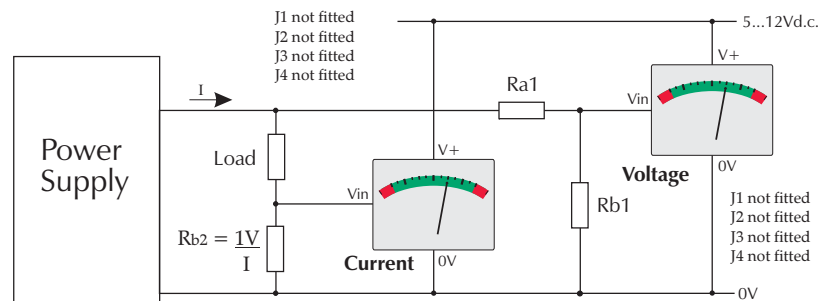

Simultaneous d.c. Voltage and Current Indication.